

## DISTAGON CFi 4/50



### CLOSE FOCUS RANGE DATA:

Minimum distance object to film	0.50 m
Corresponding distance object to front lens	0.33 m
Maximum image scale	1: 6.4
Corresponding area of coverage	35 x 35 cm
Corresponding exposure reduction	0.3 f-stop

### ENTRANCE PUPIL POSITION

129 mm in front of the film plane.  
(at infinite focus setting):

The entrance pupil position is the correct position of the axis of rotation when making a panorama image by combining individual images of a scene.

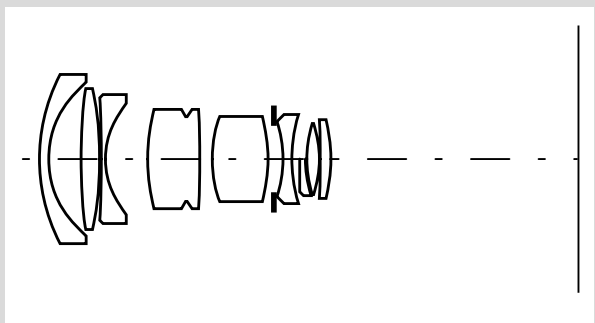

### MTF

Modulation Transfer as a function of image height at infinite focus setting.

Sagittal slit orientation drawn with continuous line and tangential with dashed. White light. Spatial frequencies 10, 20 and 40 lp/mm

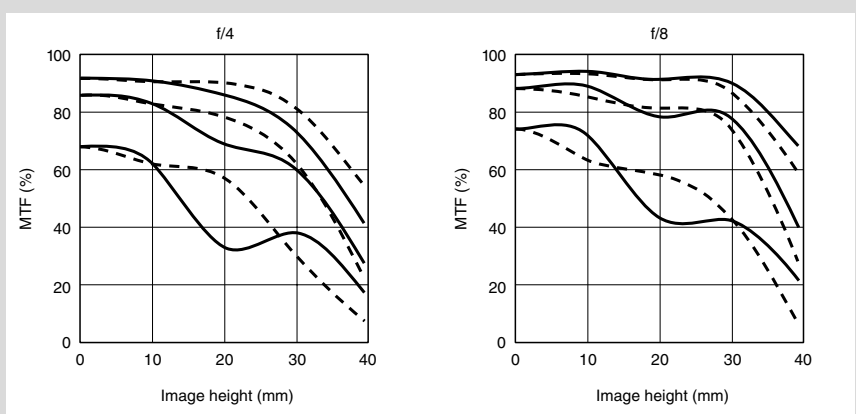

## DISTAGON CFi 4/50

### DEPTH-OF-FIELD DATA

Given distances are calculated for a blur circle diameter of 60 microns and do not include the effect of lens aberrations. For very critical photography and great enlargements this blur will be visible.

For these situations we recommend a conservative use of the DOF data. In such situations the data given for an aperture two f-stops larger should be used (for example, if shooting at f/8, use DOF data for f/4).

### Depth-of-field in meters

	f/4	f/8	f/16	f/32
∞	11 - ∞	6 - ∞	3 - ∞	1.5 - ∞
8 m	5 - 25	3.5 - ∞	2.2 - ∞	1.3 - ∞
4 m	3 - 6	2.5 - 12	1.8 - ∞	1.2 - ∞
2.5 m	2.1 - 3.1	1.8 - 4	1.4 - 14	1.05 - ∞
2 m	1.75 - 2.35	1.55 - 2.9	1.3 - 5.5	0.95 - ∞
1.6 m	1.45 - 1.8	1.3 - 2.1	1.1 - 3	0.85 - ∞
1.2 m	1.1 - 1.3	1.05 - 1.45	0.9 - 1.8	0.75 - 4
1 m	0.94 - 1.07	0.89 - 1.15	0.8 - 1.35	0.7 - 2.2
0.8 m	0.765 - 0.84	0.74 - 0.88	0.68 - 1	0.6 - 1.3
0.7 m	0.675 - 0.725	0.655 - 0.75	0.62 - 0.82	0.55 - 1
0.65 m	0.63 - 0.67	0.61 - 0.69	0.58 - 0.75	0.53 - 0.9
0.6 m	0.585 - 0.617	0.57 - 0.635	0.54 - 0.68	0.5 - 0.8
0.55 m	0.538 - 0.563	0.525 - 0.575	0.505 - 0.61	0.47 - 0.7
0.5 m	0.491 - 0.51	0.482 - 0.52	0.465 - 0.54	0.44 - 0.6

To convert meters into feet, multiply by 3.281. To convert meters into inches, multiply by 39.37